

Original design by Ray Wilson (<http://musicfromouterspace.com>)
<http://www.davidhailant.com>

David Hailant

Sheet: /
File: wsg.sch

Title: MFOS WSG in SMT

Size: A4 Date: 2018-08-29

KiCad E.D.A. kicad 5.0.0-fee4fd166ubuntu16.04.1

Rev: 1.1

Id: 1/6

Voice A Zany Frequency Indicator LED

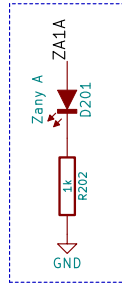

Voice A Zany Oscillator Trigger Out

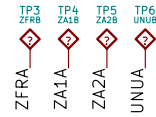
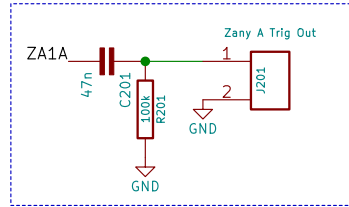

Zany A

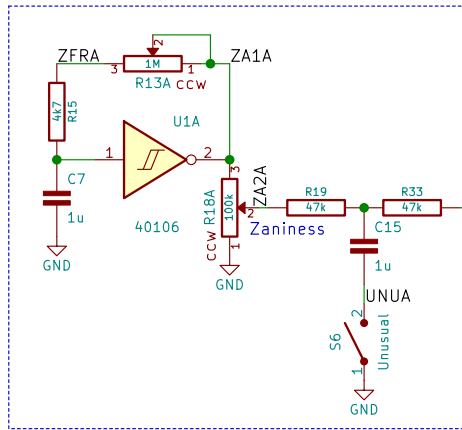

Weird A

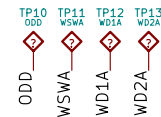
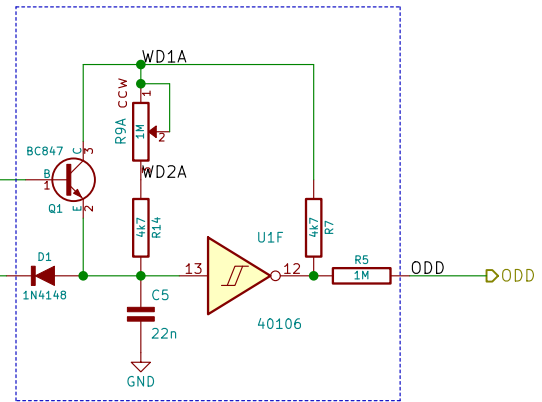

Wacky A

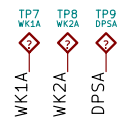
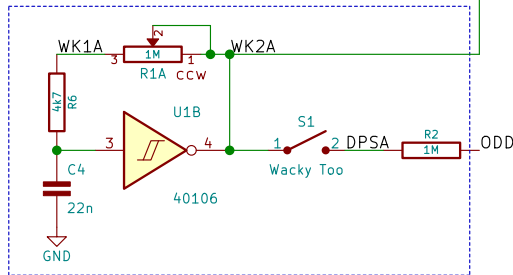

Original design by Ray Wilson (<http://musicfromouterspace.com>)
<http://www.davidhailant.com>

David Hailant

Sheet: /Voice A/
 File: voice_a.sch

Title: MFOS WSG in SMT

Size: A4 Date: 2018-08-29

KiCad E.D.A. kicad 5.0.0-fee4fd166ubuntu16.04.1

Rev: 1.1

Id: 2/6

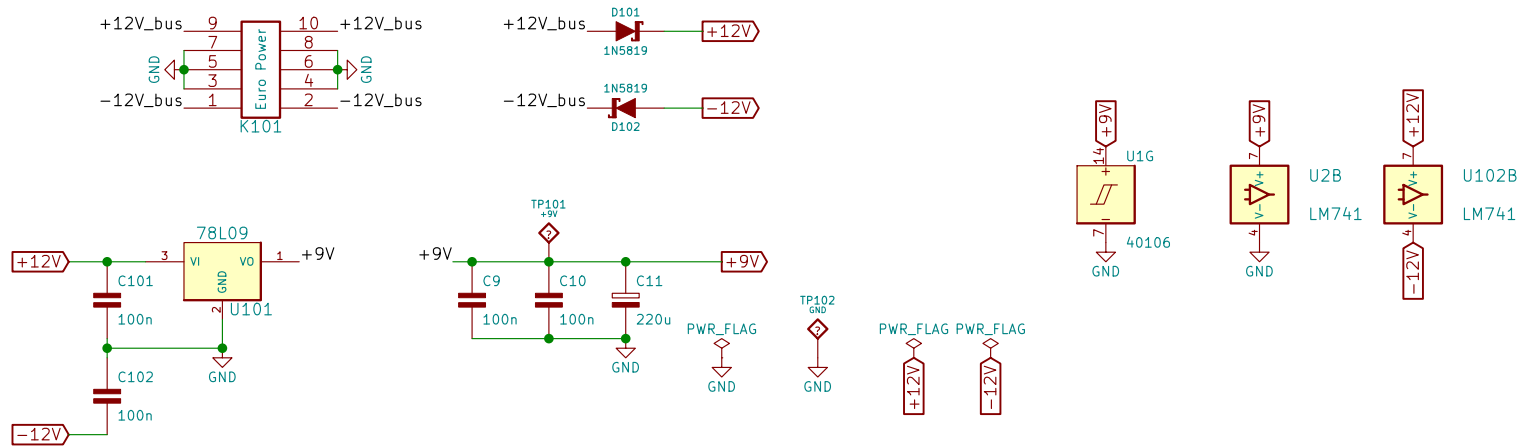

Original design by Ray Wilson (<http://musicfromouterspace.com>)
<http://www.davidhailant.com>

David Hailant

Sheet: /Power/

File: power.sch

Title: MFOS WSG in SMT

Size: A4 Date: 2018-08-29

KiCad E.D.A. kicad 5.0.0-fee4fd166ubuntu16.04.1

Rev: 1.1

Id: 3/6

Voice B Zany Frequency Indicator LED

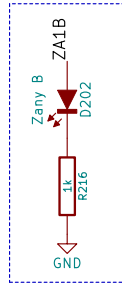

Voice B Zany Oscillator Trigger Out

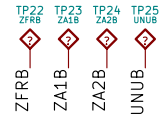
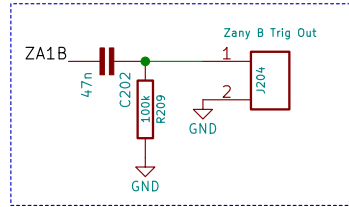

Zany B

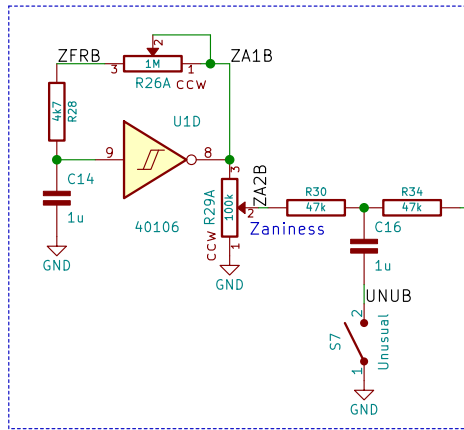

Weird B

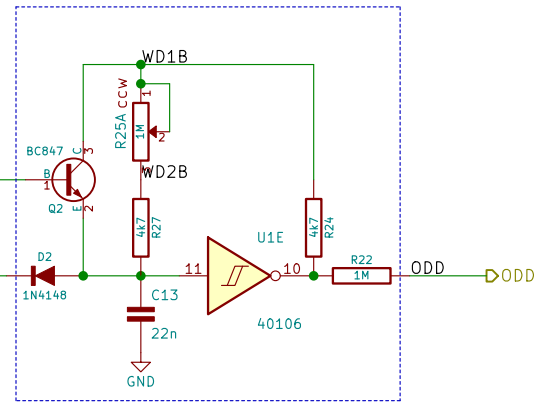

Wacky B

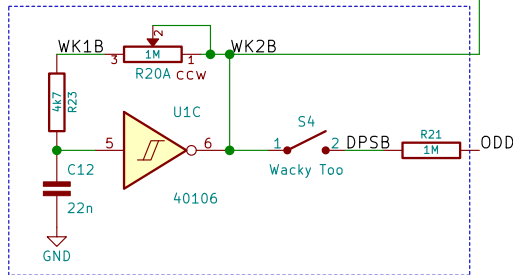

Original design by Ray Wilson (<http://musicfromouterspace.com>)
<http://www.davidhailant.com>

David Hailant

Sheet: /Voice B/
 File: voice_b.sch

Title: MFOS WSG in SMT

Size: A4 Date: 2018-08-29

KiCad E.D.A. kicad 5.0.0-fee4fd166ubuntu16.04.1

Rev: 1.1

Id: 5/6

Potentiometers:
<https://www.thonk.co.uk/shop/alpha-9mm-pots/>
<http://smallbear-electronics.mybigcommerce.com/alpha-single-gang-9mm-right-angle-pc-mount/>
<https://www.musikding.de/Pot-9mm-100k-lin-Print-vertical>
<https://erthenvar.myshopify.com/collections/9mm-potentiometers/products/smooth-shaft-vertical-pot>

Buttons:
<https://www.musikding.de/Nose-Knob-orange>
<http://smallbear-electronics.mybigcommerce.com/knurled-colored-caps/>

Jacks (PJ301BM):
<https://erthenvar.myshopify.com/collections/accessories/products/3-5mm-vertical-jacks>
<https://www.thonk.co.uk/shop/3-5mm-jacks/>
<http://www.qingpu-electronics.com/en/products/wq-pj3010bm-34.html>

Front Panel Layout
 Eurorack Standard
 Aluminium 2mm Thickness
 Height 3U, Width 18HP (128.40mm x 91.10)

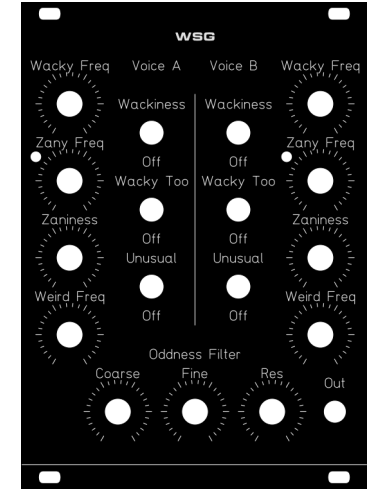

Front panel frontpanel:frontpanel-20171005

PCB

Label

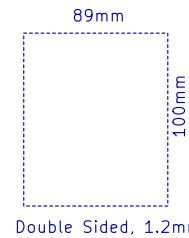

M3 PCB Mounting Holes (grounded)

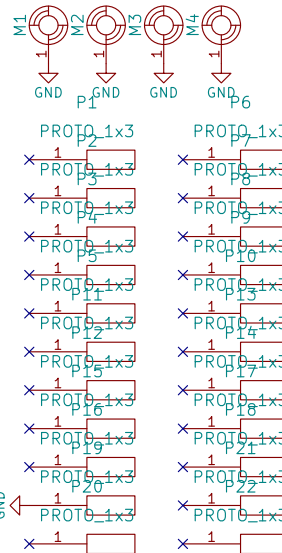

Model P09x5N (Top Adjust, PCB pins, up to 2 gangs)

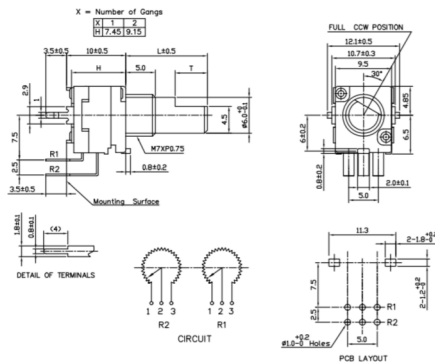

Original design by Ray Wilson (<http://musicfromouterspace.com>)
<http://www.davidhailant.com>

David Hailant

Sheet: /Hardware Parts/
 File: hardware.sch

Title: MFOS WSG in SMT

Size: A4 Date: 2018-08-29

KiCad E.D.A. kicad 5.0.0-fee4fd166ubuntu16.04.1

Rev: 1.1

Id: 6/6