

Calibration procedure:  
 Set a low Freq. (Eg. 100Hz) then apply 1V CV.  
 Frequency MUST exactly double.  
 If lower, turn R8 to make freq. LOWER.  
 If higher, turn R8 to make freq. HIGHER.  
 Remove CV. Set again to low freq (100Hz) and apply 1V CV.  
 Repeat until frequency doubles for each volt added on CV.

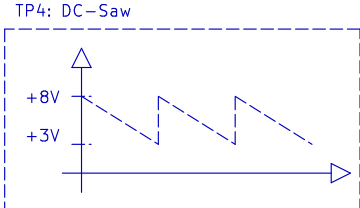

Power Interface

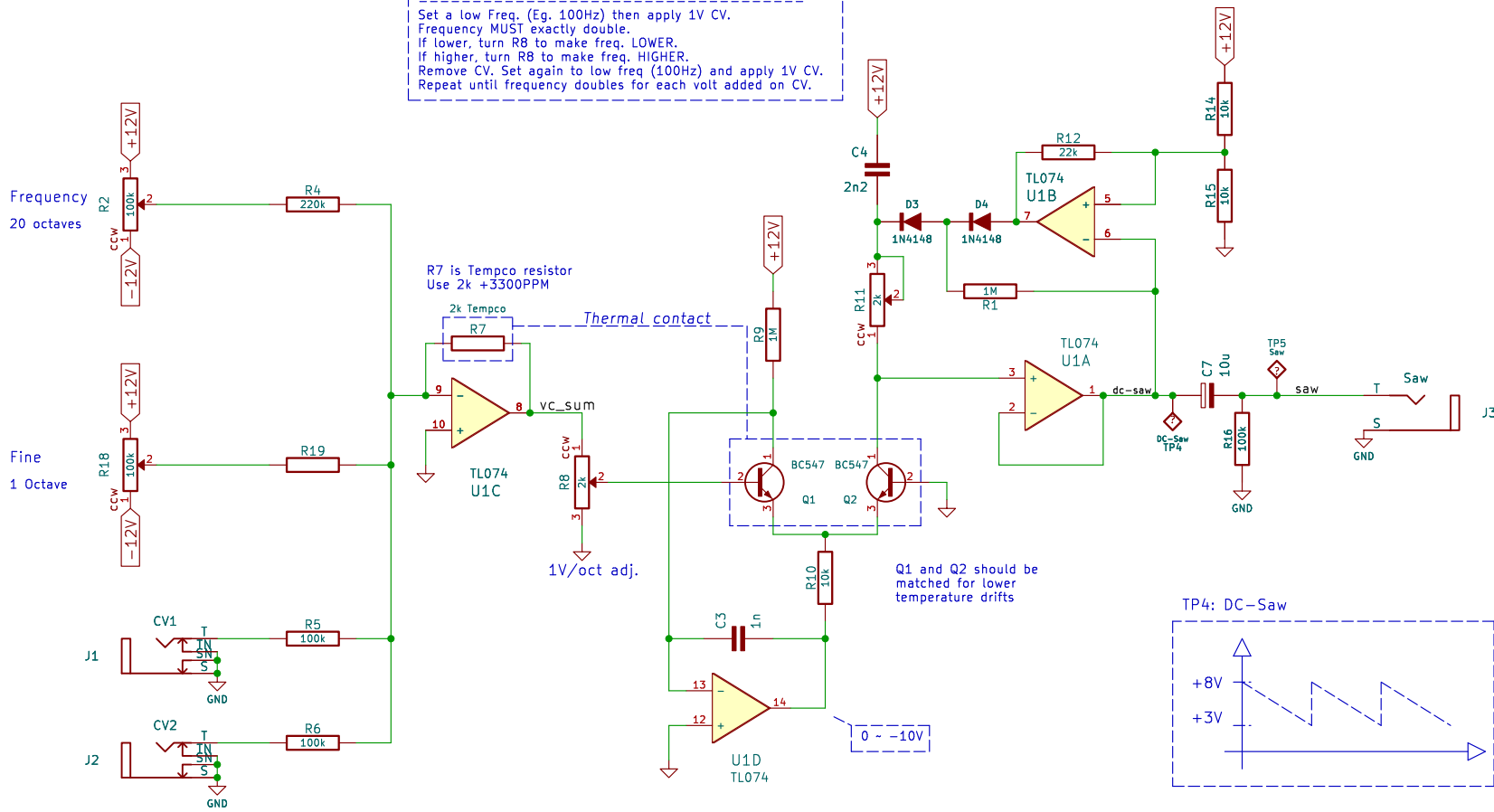
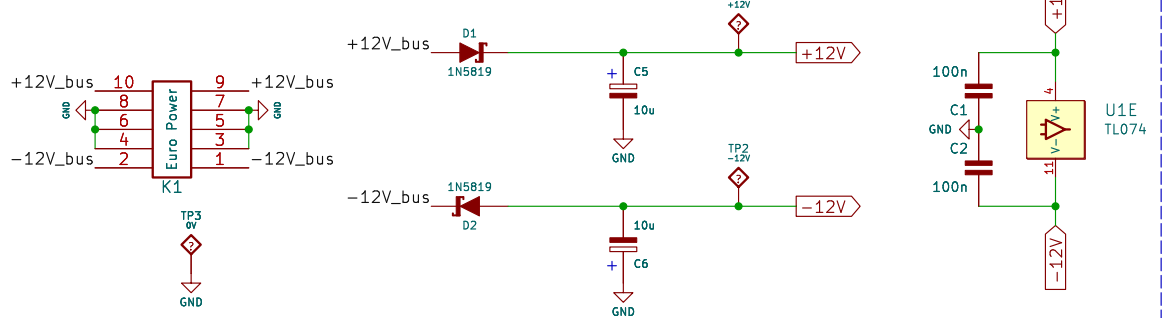

- Revision History  
 2021-05-04 V1.0:  
 \* Initial Release
- V1.1:
  - \* R1, R3: removed
  - \* R4: 220k (was 100k)
  - \* R17, R20: removed
  - \* R18: 100k (was 10k)
  - \* R19: 2M2 (was 100k)
  - \* R13: removed
  - \* R12: 22k (was 220k)
  - \* Added R1 (1M)
  - \* Added D4 (1N4148)

www.davidhailant.com  
**David Hailant**  
 Sheet: /  
 File: vco.kicad\_sch

<b>Title: Simple VCO</b>	
Size: A4	Date: 2022-05-16
KiCad E.D.A. 8.0.9	Rev: 1.1
	Id: 1/2

-  FP Silkscreen
-  Texture
-  Euronack front panel side view

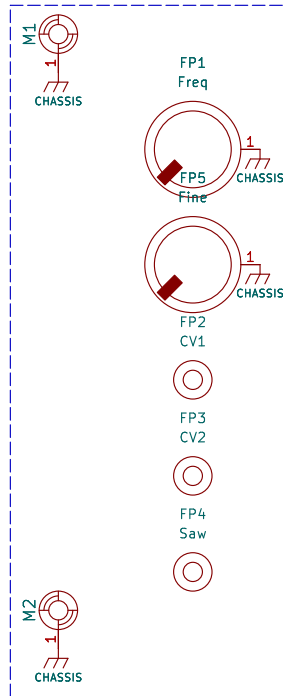

www.davidhailant.com

**David Hailant**

Sheet: /Front Panel/

File: frontpanel.kicad\_sch

**Title: Simple VCO**

Size: A4

Date: 2022-05-16

**Rev: 1.1**

KiCad E.D.A. 8.0.9

Id: 2/2