

<https://www.davidhailant.com>

David Hailant

Sheet: /

File: vcf_12db.sch

Title: MS20 VCF

Size: A4 Date: 2021-04-29

KiCad E.D.A. kicad (5.1.9)-1

Rev: 1.2

Id: 1/3

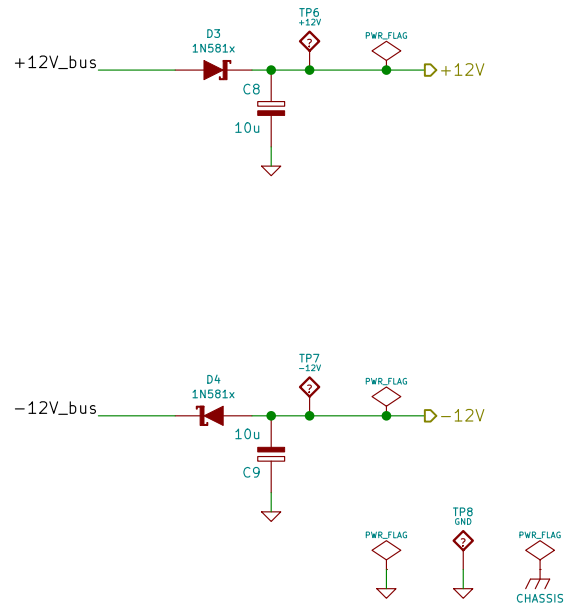
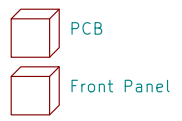
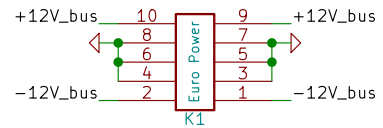

https://www.davidhailant.com David Hailant	
Sheet: /Eurorack Power Interface/ File: euro_power_10.sch	
Title: MS20 VCF	
Size: A4	Date: 2021-04-29
KiCad E.D.A. kicad (5.1.9)-1	Rev: 1.2
	Id: 2/3

- FP Layout
- FP Silkscreen
- FP Side view
- FP Texture

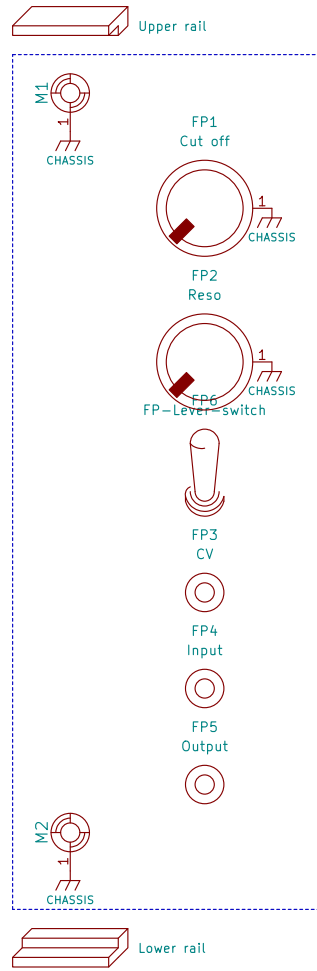

- Frequency Knob
- Resonance Knob
- Push button Cap

Formerly based on MFOS SLMS VCF section
<https://www.davidhailant.com>

David Hailant

Sheet: /Front Panel/
 File: frontpanel.sch

Title: MS20 VCF

Size: A4 Date: 2021-04-29
 KiCad E.D.A. kicad (5.1.9)-1

Rev: 1.2
 Id: 3/3