

\*: Lower R or High intensity LED

www.davidhailant.com

David Hailant

Sheet: /

File: midi8d\_pwm.kicad\_sch

**Title: MIDI 8 Digital Outputs +**

Size: A4

Date: 2023-12-26

KiCad E.D.A. kicad 7.0.10-7.0.10-ubuntu20.04.1

Rev: 1.0

Id: 1/5

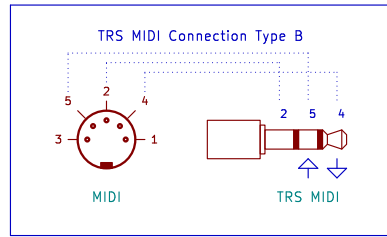
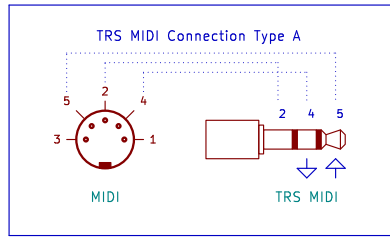

4 - current source  
5 - current sink  
2 - shield

Pin view of male plug (connector side)  
(Or Cable view of female plug/socket)

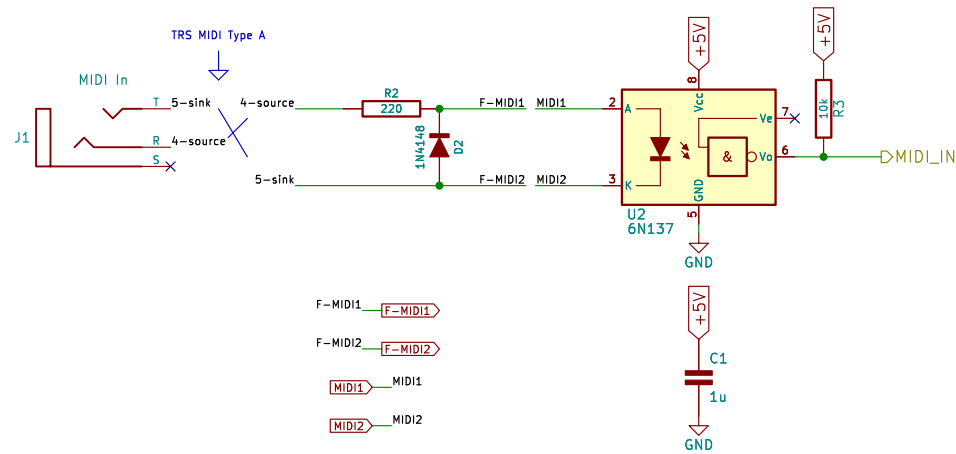

www.davidhailant.com

David Hailant

Sheet: /MIDI input port/  
File: midi\_in\_port.kicad\_sch

**Title: MIDI 8 Digital Outputs +**

Size: A4 Date: 2023-12-26  
KiCad E.D.A. kicad 7.0.10-7.0.10-ubuntu20.04.1

Rev: 1.0  
Id: 2/5

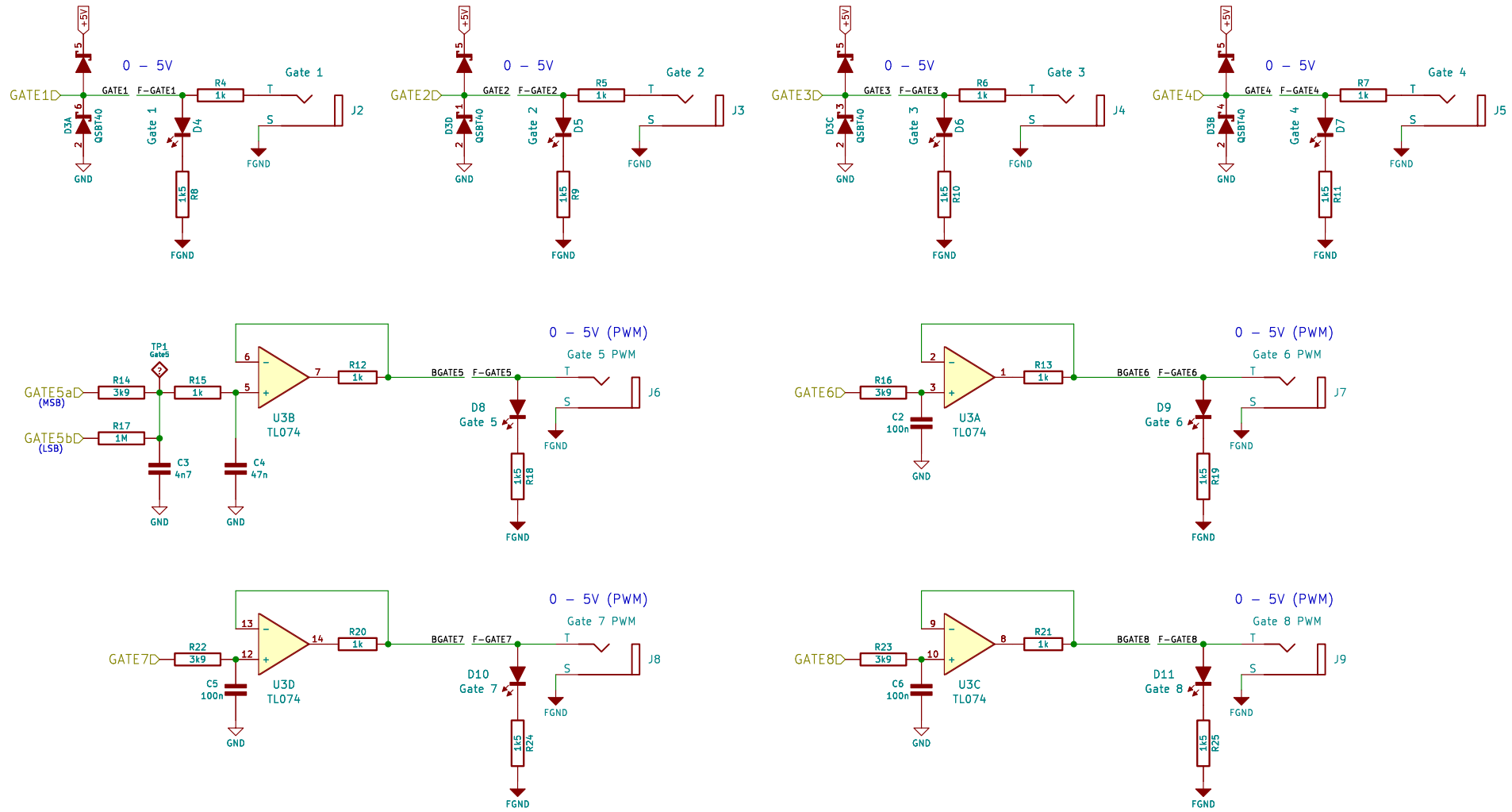

- GATE1 GATE1 F-GATE1 F-GATE1
- GATE2 GATE2 F-GATE2 F-GATE2
- GATE3 GATE3 F-GATE3 F-GATE3
- GATE4 GATE4 F-GATE4 F-GATE4
- BGATE5 BGATE5 F-GATE5 F-GATE5
- BGATE6 BGATE6 F-GATE6 F-GATE6
- BGATE7 BGATE7 F-GATE7 F-GATE7
- BGATE8 BGATE8 F-GATE8 F-GATE8

www.davidhailant.com  
**David Hailant**  
 Sheet: /Gate Outputs/  
 File: gate\_out.kicad\_sch

---

**Title: MIDI 8 Digital Outputs +**

Size: A4	Date: 2023-12-26
KiCad E.D.A. kicad 7.0.10-7.0.10-ubuntu20.04.1	
Rev: 1.0	
Id: 3/5	

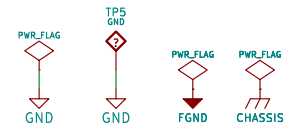
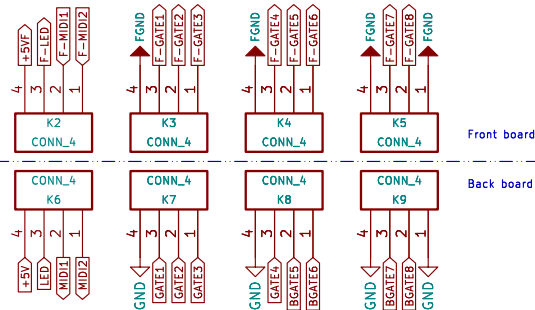
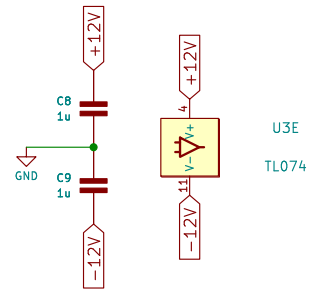
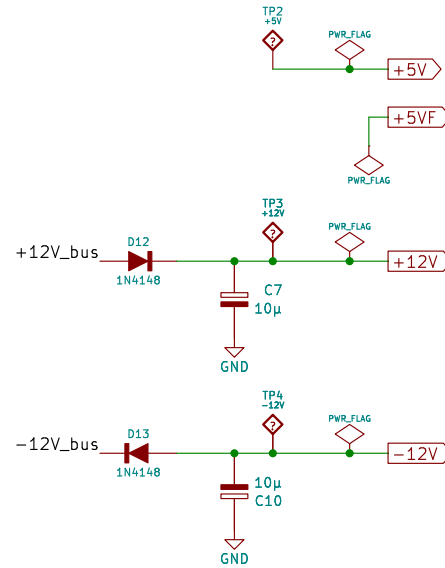
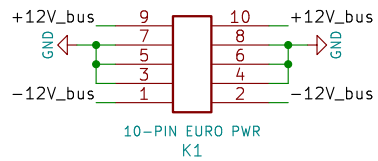

www.davidhailant.com

David Hailant

Sheet: /Power Supply/

File: power.kicad\_sch

**Title: MIDI 8 Digital Outputs +**

Size: A4

Date: 2023-12-26

Rev: 1.0

KiCad E.D.A. kicad 7.0.10-7.0.10-ubuntu20.04.1

Id: 4/5

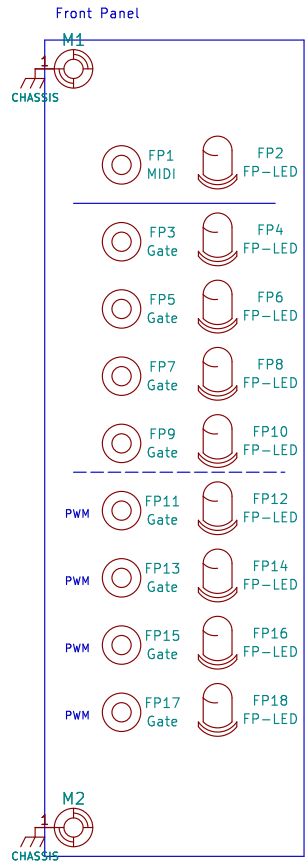
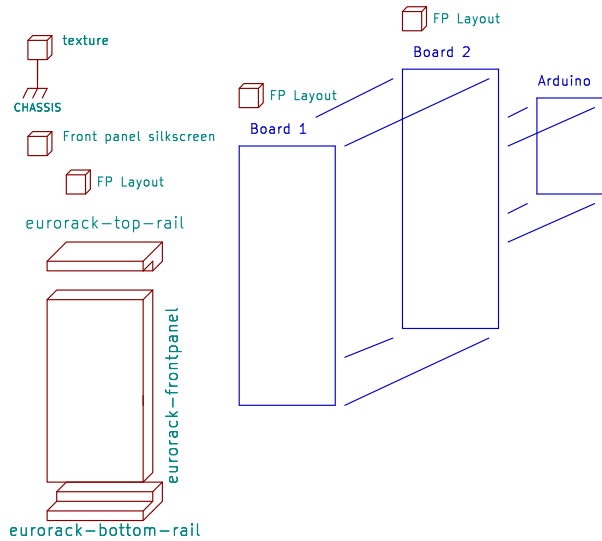

www.davidhailant.com

**David Hailant**

Sheet: /Front Panel/

File: frontpanel.kicad\_sch

**Title: MIDI 8 Digital Outputs +**

Size: A4 Date: 2023-12-26

**Rev: 1.0**

KiCad E.D.A. kicad 7.0.10-7.0.10-ubuntu20.04.1

Id: 5/5