

- DIP14
- Front panel

Powered at -12/+12 V, output will swing between approx. -10/+10 V

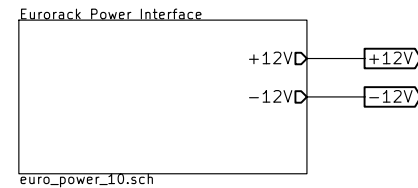
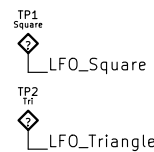
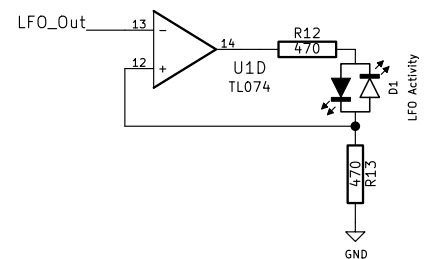
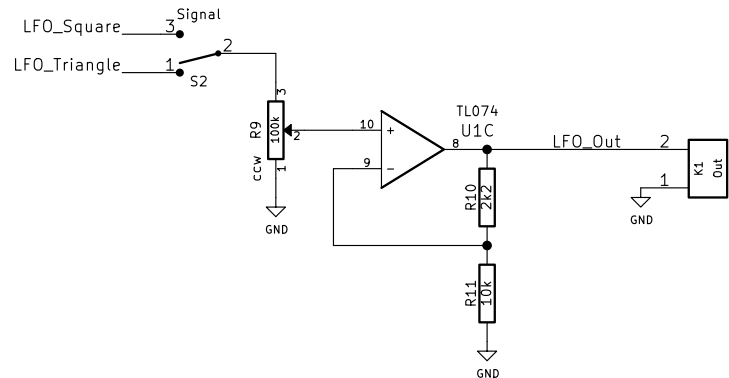

<http://www.davidhailant.com>

David Hailant

Sheet: /

File: lfo.sch

Title: Simple LFO

Size: A4 Date: 2019-06-16

KiCad E.D.A. kicad (5.1.2)-1

Rev: 1.3

Id: 1/2

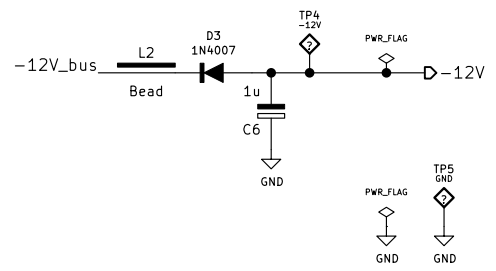
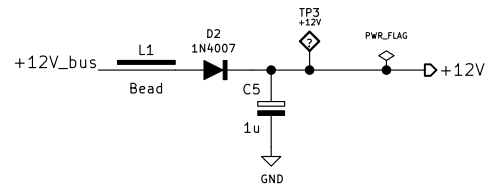
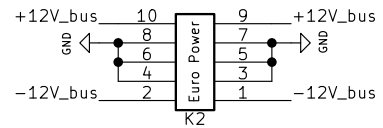

<http://www.davidhailant.com>

David Hailant

Sheet: /Eurorack Power Interface/
File: euro_power_10.sch

Title: Simple LFO

Size: A4 Date: 2019-06-16

KiCad E.D.A. kicad (5.1.2)-1

Rev: 1.3

Id: 2/2