

Simple LFO 1.4

Simple and easy to build LFO module for Analog Synthesizers.

1. Features

- Square and Triangle waveforms (90° phase shifted)
- Dual range frequencies
- Frequency ranges from 2.5 mHz up to 250 Hz
- Very stable
- Buffered Output
- Compatible with Eurorack Power Bus System (connector and voltages)
- Low power
- Versatile configuration

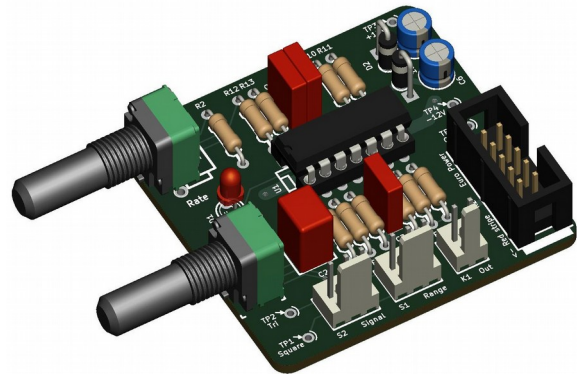

2. Application

Low frequency oscillator for slow variations of Control Voltage inputs on Analog Synthesizers modules.

Hi frequency oscillator for FM style effects.

Audio oscillator (drone).

3. Description

The Simple LFO module is a *Low Frequency* Square and Triangle Oscillator, designed to be integrated into an analog synthesizer. It is compatible with the Eurorack format: 10-pin power supply connector and voltages (+12V, 0V and -12V).

The frequency, ranging from 2.5 mHz up to 250 Hz (audio domain), is adjusted with the potentiometer R1 (Rate). There is no Voltage Control (CV) input.

Powered at -12 / +12V, the maximum output amplitude swings between -10 / +10V peak-to-peak. The output signal can be attenuated with the potentiometer R9 (Amplitude).

The waveform is selected between Triangle and Square with the switch S2 (Signal).

If required, both waveforms can be used, separately, but in this case, only one waveform can be attenuated via R9. Also, there's a phase shift of 90° between the two signals: the square wave is “low” when the triangle waveform is “going up”, and the square wave is “high” when the triangle wave is “going down”.

The oscillator is based around two operational amplifiers. The first op amp (U1A, R1-R4, C1,

C2) is an *integrator* circuit. The second part (U1B, R5-R8) is a *Schmitt trigger* comparator.

The output is buffered, insuring a stable frequency, independent of the output load. It can be directly linked to the CV input of any voltage controlled analog module.

4. Characteristics

Nominal Power supply voltages	-12 / 0 / +12 volts
Power consumption @ -12/+12V	10 mA per rail
PCB dimensions	5 x 5 cm
Output Voltage	-10 / +10 volts max

Table 1: Characteristics

5. BOM







Designation	Qty	Reference
10nF MKS 5mm pin pitch	1	C1
100nF MKS 5mm pin pitch	2	C3 C4
1μF MKS* 5mm pin pitch	1	C2
1μF 35V Aluminum (<i>polarized!</i>)	2	C5 C6
LED Bi-color (If 10mA, Vf 2V)	1	D1
1N4007	2	D2 D3
Jack mono (wired)	1	K1
HE10/header 2x5 pins	1	K2
470 Ohm 0.25W 5% 	3	R2 R12 R13
4k7 Ohm 0.25W 5% 	1	R7
10k Ohm 0.25W 5% 	2	R8 R11
2k2 Ohm 0.25W 5% 	1	R10
47k Ohm 0.25W 5% 	1	R4
100k Ohm 0.25W 5% 	3	R3 R5 R6
100k Ohm pot. (2.5 or 5mm pin pitch) <i>Alpha RD901F</i> style ¹	1	R1
100k Ohm pot. (2.5mm pin pitch) <i>Alpha RD901F</i> style	1	R9
SPDT switch + cables + 3 pin connector	2	S1 S2
TL074 or equivalent	1	U1
14 pin DIL socket	1	U1

Table 2: Bill Of Material

¹ See text for differences between various types of potentiometers

6. Build Instructions

Some potentiometers have a protruding tab which could prevent a flush mount on the front panel. With pliers, remove the potentiometer protruding tab before soldering.

Start by soldering small components: first the resistors, followed by the DIL socket. Then, continue with bigger components: small capacitors, connector K1, S1, S2 and S3, bigger capacitors, etc.

It is recommended to place the potentiometers on the panel before soldering them.

Resistors

Resistors are not polarized. It's best practice to align them in the same direction, for better reading of the color coded rings.

Color	1 st ring	2 nd (and 3 rd) ring	3 rd (or 4 th) ring		suffix	4 th (or 5 th) ring
Black	0	0		10 ⁰		
Brown	1	1	0	10 ¹		±1%
Red	2	2	00	10 ²		±2%
Orange	3	3	000	10 ³	k (kilo)	
Yellow	4	4	0000	10 ⁴	0k	
Green	5	5	00000	10 ⁵	00k	
Blue	6	6	000000	10 ⁶	M (mega)	
Violet	7	7	0000000	10 ⁷	0M	
Gray	8	8	00000000	10 ⁸		
White	9	9	000000000	10 ⁹		
Gold						±5%

Table 3: Resistor Color Codes

Capacitors

MKS/MKT plastic or ceramic capacitors are not polarized.

Aluminum electrolytic capacitors are polarized. The longest leg is the positive side.

The negative side is identified, both on the component and the PCB, with a thick white marking.

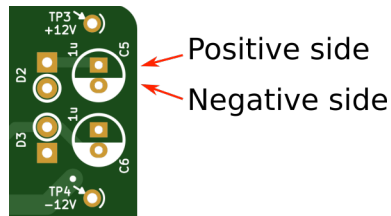

Also, the positive pin goes to the square shaped pad and the negative pin is connected to the round shaped pad.

Diodes

Diodes D2 and D3 are polarized. They are mounted vertically, over the round shaped pad (the one surrounded with a white circle). The Cathode (the white band marking) is **up**.

These diodes will prevent potential damages caused by a reversed polarity of the power supply.

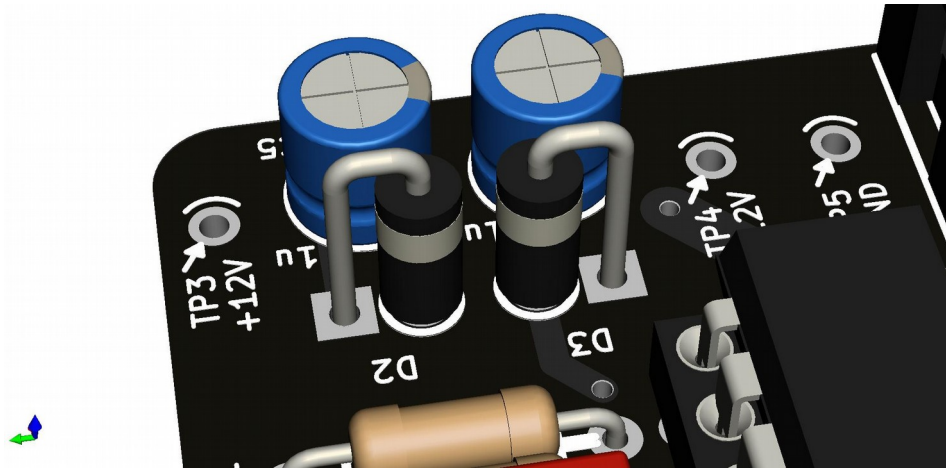

LED

Fold the LED legs at 90° approximately 5~6mm from the body. Ideally, it's easier to first mount the front panel, then solder the LED in place.

LEDs are polarized. The longest pin is the positive side (Anode). Silkscreen shows a “flat” side: it's the negative pole (Cathode).

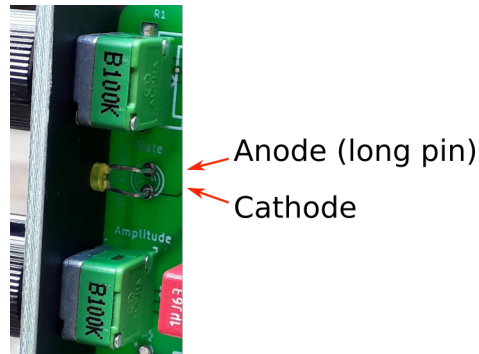
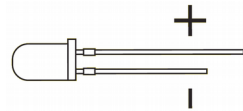

Switches

Use SPDT switch for frequency Range (S1) and for signal shape (S2), depending on the application. For each SPDT switch, you need the corresponding wires and connectors.

Potentiometers

Potentiometer R1 (Rate) can be either a 9mm or a 16mm type. 9mm type is recommended for narrower front plates (see below the 4HP example for a single LFO module).

The 16mm type is recommended in larger setups (see the 6HP example with a dual module configuration).

- 9mm potentiometer fits in 2.54mm footprint.
- 16mm potentiometer fits in 5.08mm footprint.

R9 (Amplitude) is a potentiometer, 9mm only.

Note that Alpha 9mm and 16mm potentiometers have different heights. 16mm potentiometer is taller than 9mm potentiometer: The shaft axis will be unaligned with the potentiometer R9. It is 6.35mm higher.

Before soldering the two potentiometers, it is best practice to bolt them in place on the panel and solder them *after* onto the PCB. Try to avoid soldering before mounting on the panel because when you tighten the components to the front panel, it creates a mechanical tension and weakens the solder joints.

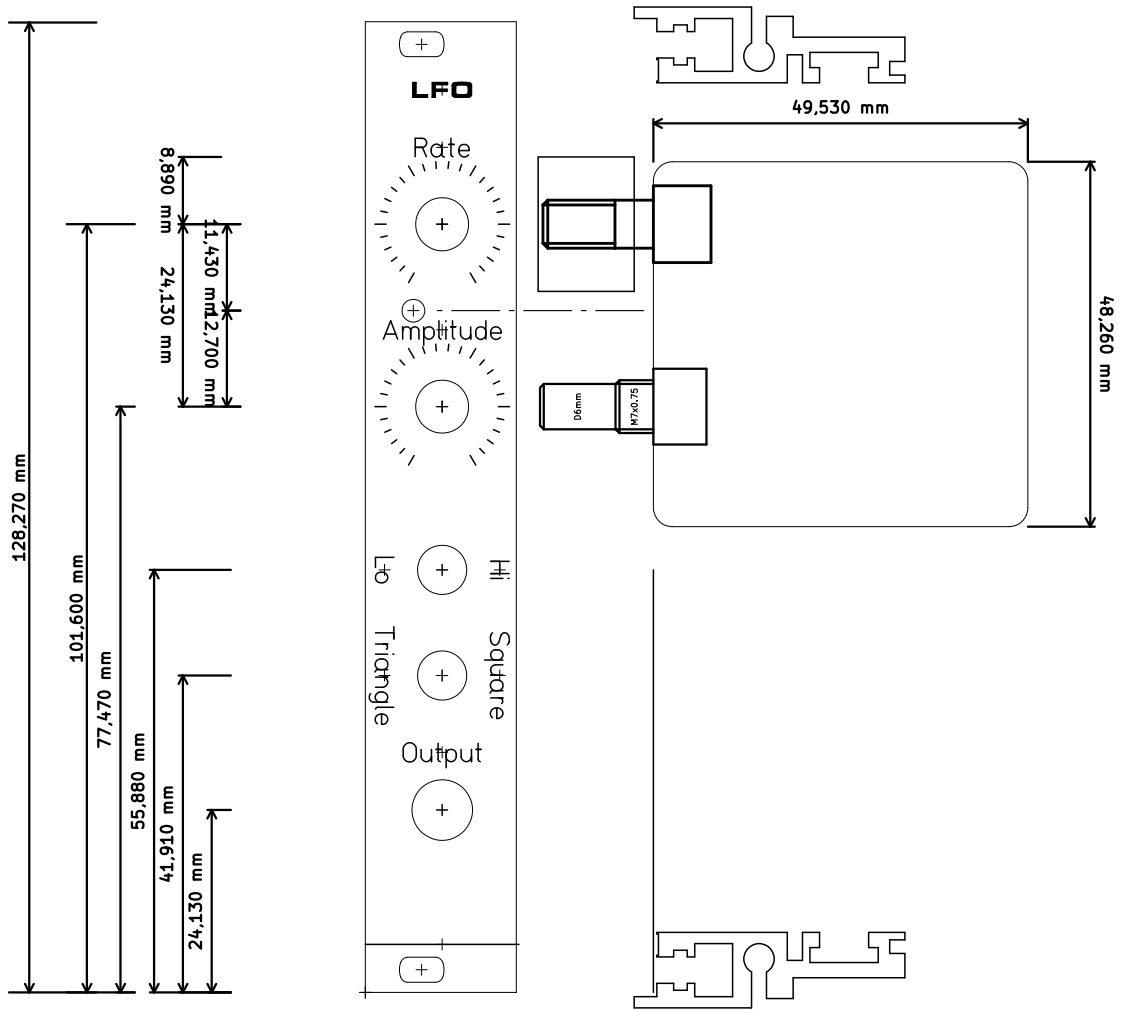

Figure 1: Layout and dimensions

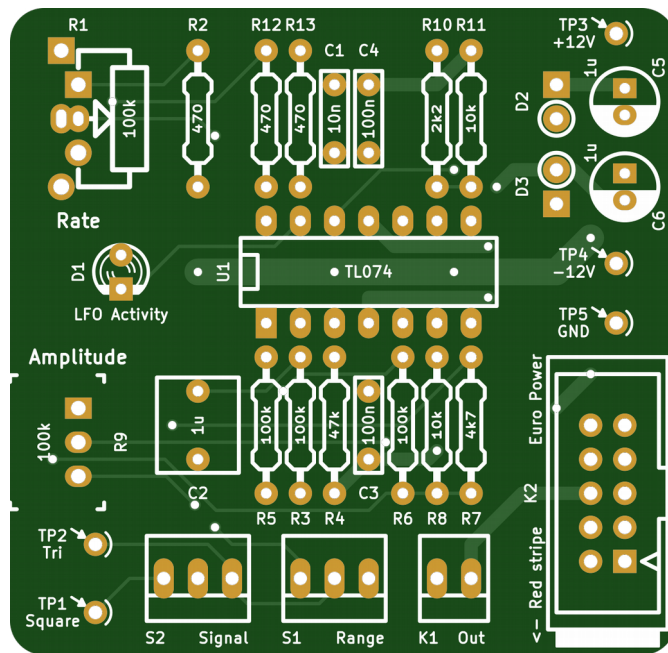

Figure 2: Components Overlay

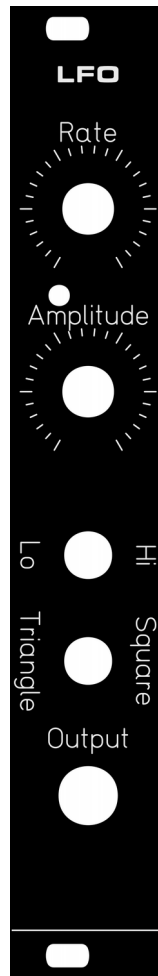

Figure 3: Suggested Front Panel design

Front Panel Components Cutouts

Component	Hole diameter (mm)
Alpha style 9 or 16mm Potentiometer	7
Cliff Jack Connector	8
3mm LED	3
Standard SPDT lever switch	6.5

Table 4: Usual Front Panel Cutout Dimensions

7. Powering and testing the module

Before powering your module DOUBLE CHECK EVERYTHING!

Then, check again.

“Red Stripe” label shows the -12V Power Rail and should be the “lower” side of the Power Connector (the arrow should point toward the floor). This is a common practice in Eurorack Synths, not an absolute truth. **Never trust the red stripe.**

Pins	Polarity
1, 2	-12V
3 to 8	0V (“Ground” or “GND”)
9, 10	+12V

Table 5: Power Input Pin-out

Verify twice you connected the right polarity and the right voltage values before turning on your PSU. If everything is fine, you should be able to see the LED blinking. The rate is modified by the potentiometer position.

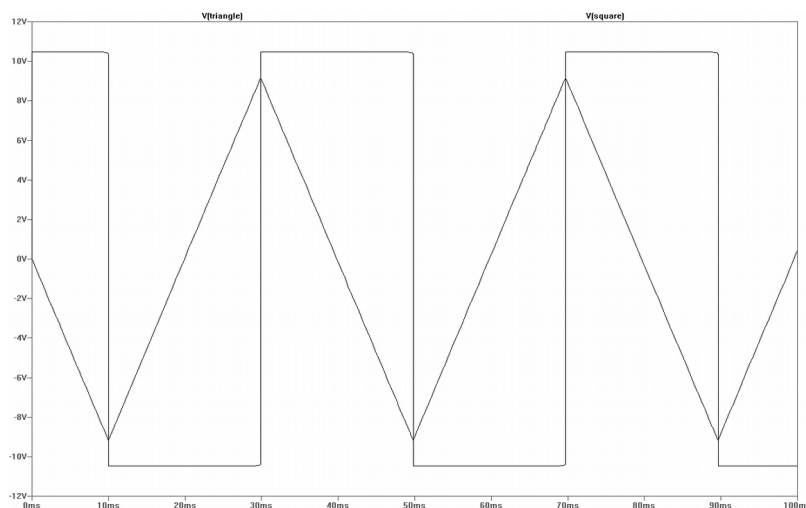

Figure 4: Square and Triangle Outputs

8. Contacts

Any question or problem? Please contact me:

david_haillant@yahoo.fr

<http://www.davidhaillant.com/category/electronic-projects/simple-lfo/>



9. Schematics

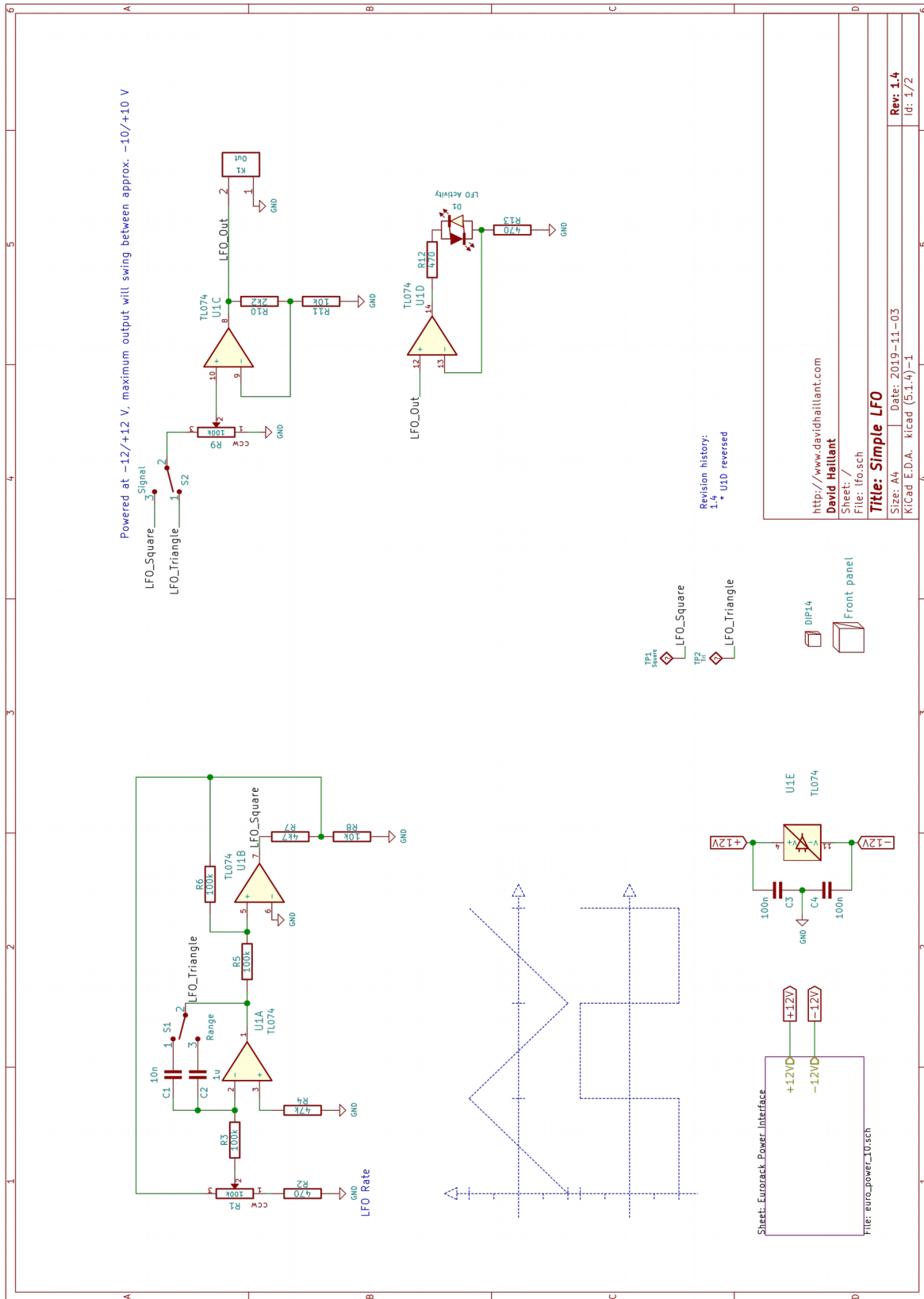

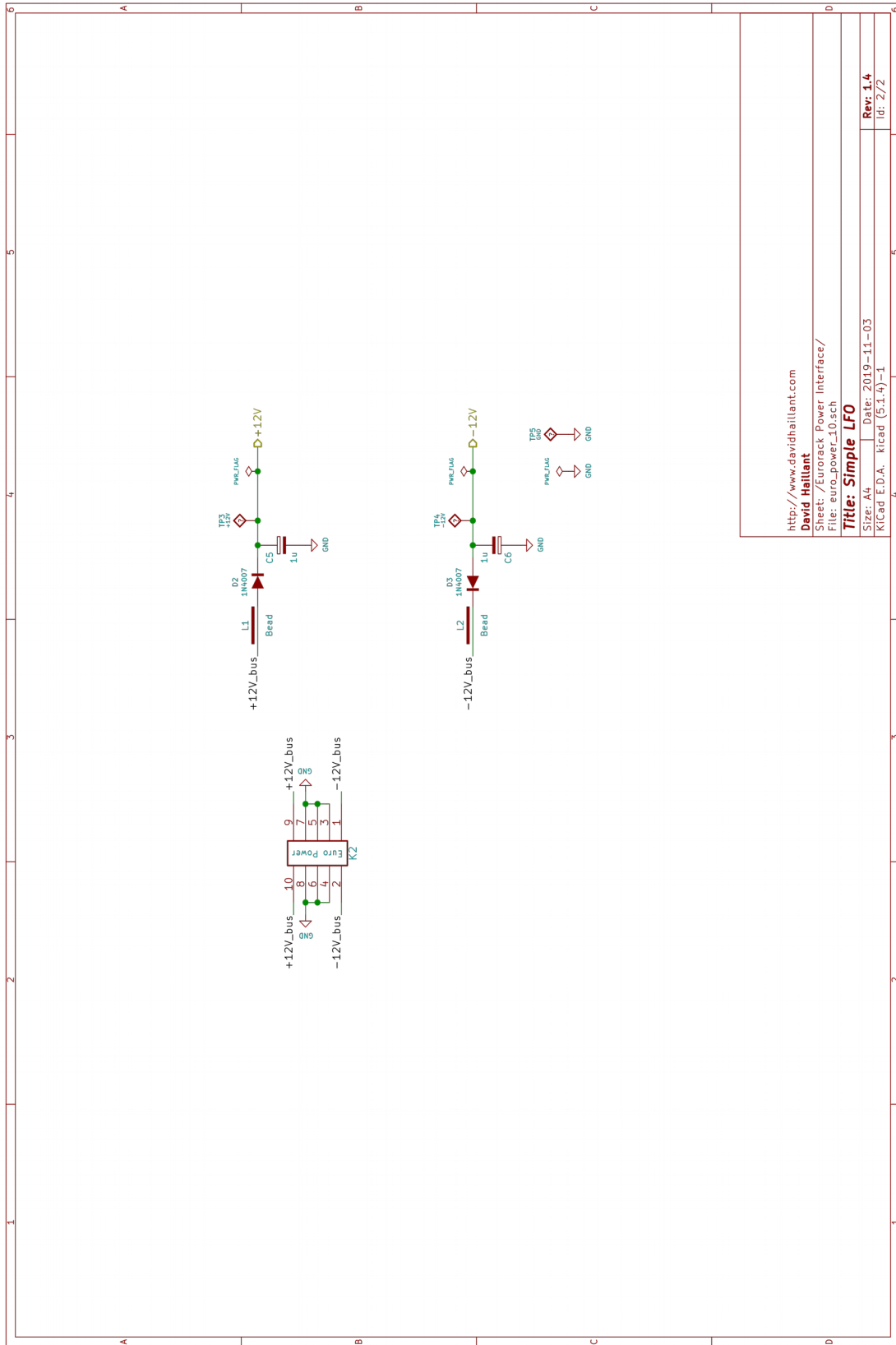

Figure 5: Eurorack Power Bus Interface